

Thermobolt

Flangebolts for Gas Turbine Exhaust

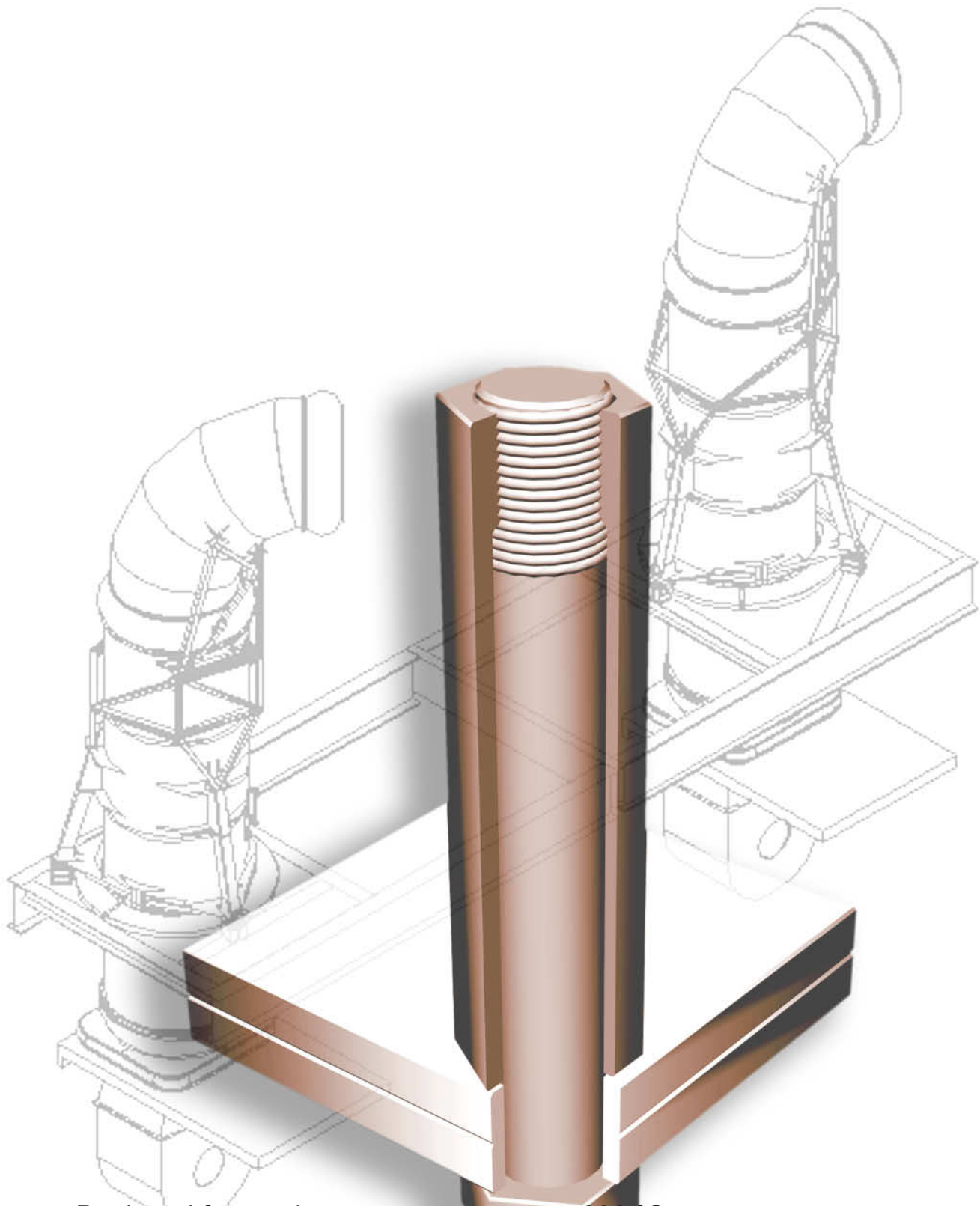

- Designed for service temperatures up to 600 °C.
- Designed for optimal stretch within elastic range.
- Maintains prestress after being exposed to mechanical shock loads and temperature gradients.

Thermobolt

Gas Turbine Exhaust Ducts.

Availability and Reliability.

Gas Turbines are increasingly being used in industrial applications, as in onshore and offshore oil and gas industry, ship propulsion, and land based power generation.

Common for the installations is that plant downtime leads to significant economic consequences, thus high demands to availability and reliability are set forth.

Damages to Gas Turbine Exhaust Ducting.

Leakages from turbine exhaust ducting are a common operational problem, often caused by loose duct flange bolt connections.

Leakages in gas turbine exhaust ducting may occur after only few hours of operation, and may cause damages and unwanted conditions such as:

- Exposure of hot exhaust gas to zone classified areas.
- Damages to expansion bellows.
- Flange gasket damage.
- Duct structural steel deformations due to temperature gradients.
- Turbine alarm and trip, due to high temperature in turbine enclosure.
- Damage to thermal insulation.
- Cosmetic damages.
- Deviation from HMS regulations.

Avoid short bolt connections.

Bolt relaxation and loss of gasket compression is caused by a variety of conditions, or a combination of conditions. Typically, temperature gradients and differential thermal growth of the exhaust duct flange thickness and bolts during the turbine start sequence, will result in stretching of the bolts, and result in reduced bolt tension and gasket compression. Another typical condition is aerodynamic vibrations and pressure surges due to swirls in the turbine exhaust collector, causing stretching of bolts and reduced gasket compression. Surge conditions may also cause damages to expansion bellows and duct structural steel, and to exhaust diverter valve and the waste heat recovery unit.

Flange bolts stretching during turbine start sequence.

In a typical flange bolt connection, the bolt clamping length is equal to the thickness of the flange being bolted. During the turbine start sequence, the duct temperature will rise and result in a growth in the flange thickness. Having a time differential in temperature rise compared to the duct flange, the bolt will be exposed to a stretch equal to the difference in thermal growth of the flange and the bolt.

The bolt resultant stress, being the bolt prestress and the additional stress due to thermal stretch, may cause plastic deformation in the bolt material. When the duct system is in stable operating temperature, the plastic deformation of the bolt plus the bolt thermal growth results in bolt relaxation and reduced gasket compression.

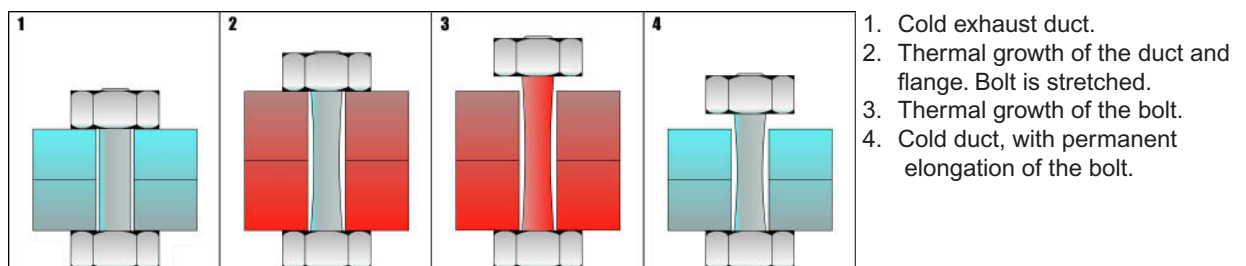

Short bolt connection with clamping length equal to flange thickness.

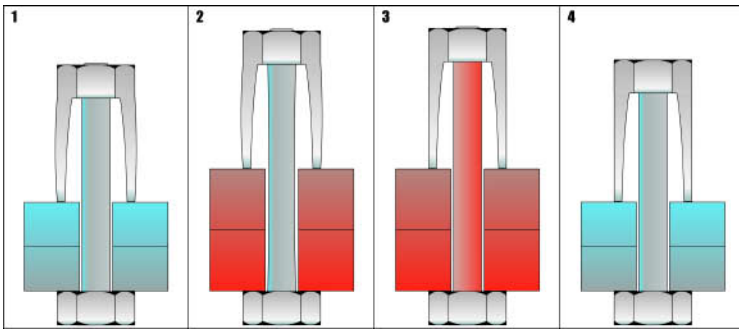

1. Cold exhaust duct.
2. Thermal growth of the duct and flange. The stretching of Thermobolt does not result in yield stress.
3. Thermal growth of Thermobolt. Prestress is maintained.
4. Cold duct. No plastic deformation of the Thermobolt.

Thermobolt with long clamping length reduces thermal stretch.

Thermobolt maintain prestress, and is not damaged by thermal cycles.

By using Thermobolt, a more slender bolt connection with increased clamping length is achieved. Design and material selection is customized for each specific application.

Thermobolt: An optimized bolt connection for gas turbine exhaust ducting.

- A Norwegian patent, developed to optimize the relation between tension length and the flange with gasket thickness.

Thermobolt:

- A slender bolt connection will have a reduced degree of material strain, for the following reason:

A given load is required to stretch a bolt to ΔL . By an increased bolt length, a reduced load will result in the same bolt ΔL . Accordingly, a slender bolt connection will be exposed to a reduced load when stretching the bolt to ΔL , as opposed to a shorter bolt being stretched to the same ΔL
- Designed to secure that the resultant of prestress and stress increase due to thermal stretch is not reaching the bolt material σ proof stress level.
- Maintains prestress, and will not loosen due to stretch as result of temperature gradients.
- Stress increase in the Thermobolt as a result of thermal growth is approximately 20% of the stress increase in a bolt with clamping length equal to the thickness of the flanges being bolted.
- Designed for an operating temperature of 600°C.
- When clamping a flange in a material different from the bolt, Thermobolt can optionally be supplied with Ceramic Coating to avoid galvanic corrosion, and also to protect the Thermobolt externals from heat radiation.
- Customized design for each individual application.
- Installation procedure with calculated prestress for each specific application

Typical design parameters for Thermobolt are:

- Material selection
- Operating temperature
- Temperature gradients
- Static and dynamic loads
- Flange geometry
- Number of bolts
- Bolt diameter
- Gasket properties
- Bolt clamping length
- Bolt stretch
- Bolt resultant load
- Embedment relaxation
- Material Creep



Thermobolt installed on an LM2500 Exhaust Duct.

Typical reasons for loose bolt connections:

- Incorrect bolt installation prestress.
- Interactive bolt-relaxation.
- Crushing of gasket.
- Incorrect use of washers.
- Coarse surface of bolt connection friction surfaces.
- Improper thread locking.
- Creep in bolt and gasket material.
- Dynamic loads.
- Embedment relaxation.



Flange and bolt temperatures in an exhaust duct, measured by thermograph.

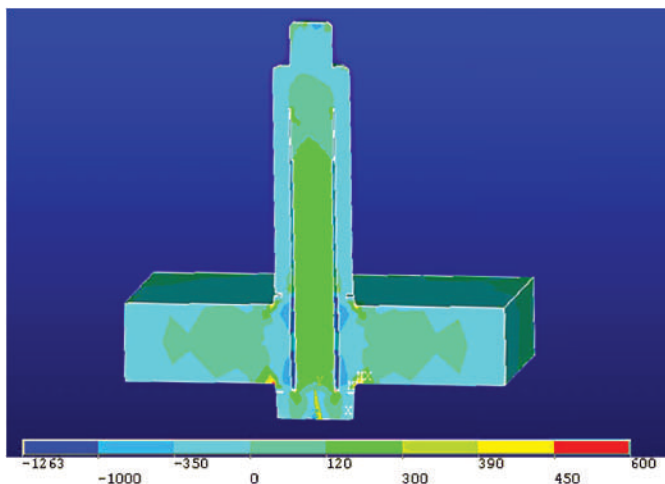

Stress increase in Thermobolt as a result of thermal stretch. The stress levels do not include prestress from bolt installation torque.

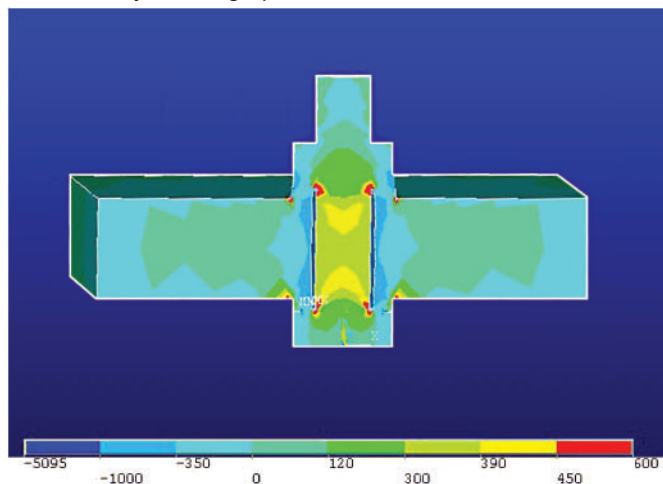

Stress increase in typical short bolt connections as a result of thermal stretch. The stress levels do not include prestress from bolt installation torque.

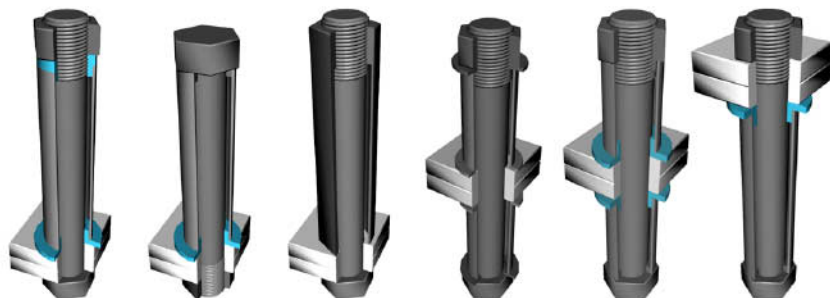

Delivery program for Thermobolt Exhaust Duct Bolting.

Thermobolt Material Selection:
B7, B8, B16, 422C, Grade 310, Inconel.

Typical Thermobolt Specification.

Bolt material:	ASTM A193 Grade B16
Nut material:	ASTM A 194 Grade B16
Design standard:	ISO
Thread type:	Self locking
Thread dimension:	M8-M48
Product marking:	16B
Ordering data:	Base material thickness Operating temperature Bolt diameter Gasket type, if applied

Inventa Power Package Services AS
Kongev. 49 A
1412 Sofiemyr
Norway

Fax: +47 66 80 33 91
Tlf: +47 66 80 33 90
www.thermobolt.no
www.thermobolt.com